



SK 1510
SK 1515
SK 3015
SK 3020
SK 4520

Portal Milling Machines SK Series



Head Office

Intelligent Labs Plus GmbH
Riedmattstrasse 10
6030 Ebikon
Switzerland

Phone: +41-798995017



www.intelligentlabs.ch

www.intelligentlabs.ch

Highest performance and productivity

The laminated profiles welded in argon gas offer benchmark for highest rigidity

Improved structure concept for X axis offer large clearance of work table.

Rigid Y-axis concept in whole range of travel

FEM-optimized design & construction

Precision in every component and detail

Highlights

Maximum stiffness with
welded laminated profiles

Precision and stability

Optimized for high speed
machining

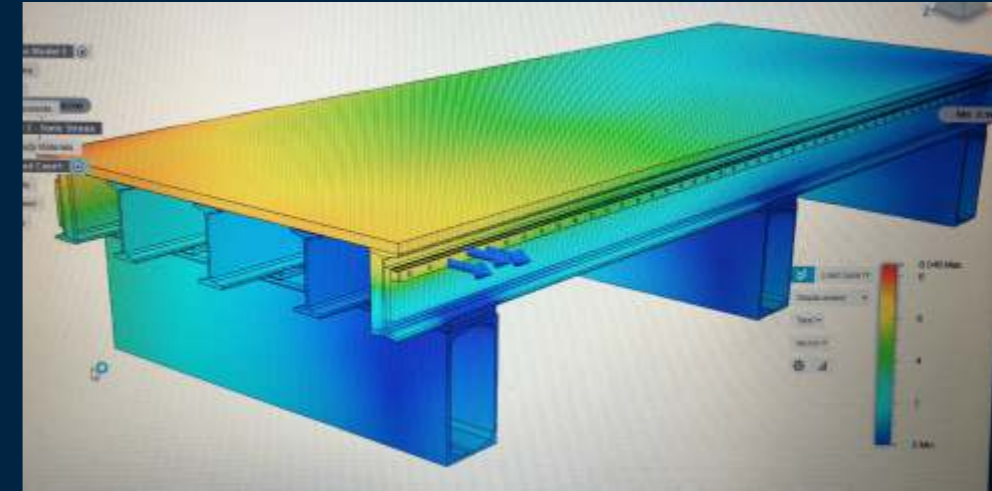
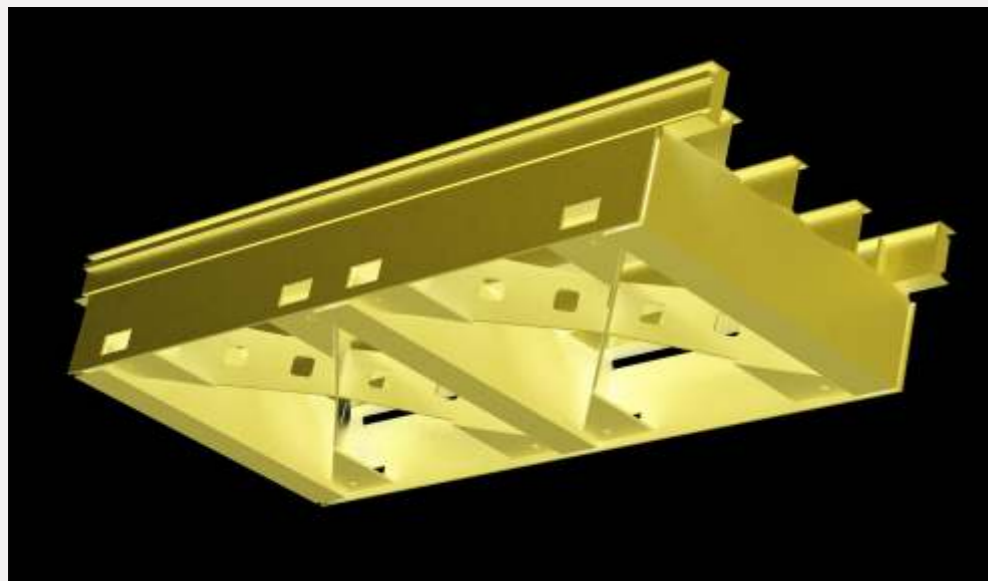

Accuracy of positioning in all axes of 20 μm without linear scales.

Thermal compensation ensures stable, precise and highest quality production process

Gudel made in Swiss transmission - 4 μm class of precision with hardened surface

Sophisticated design and large working area - combined in
the SK series

Improved ergonomics for easy handling and loading of heavy workpieces

Huge table with 3100 x 1600 mm for cutting of parts up to 1,200 kg

Small foot print 13.2 m² for SK3015

Technical Area

Work Area

Max. X travels	3,050 mm
Max. Y travels	1600 mm
Max. Z travels	300 mm

Table dimensions

Max. table load	1,200 kg
Lift length	3,100 mm
Table width	1,600 mm

Spindle cutting

Standard HSD ES350	36,000 rpm
Tool type	HSK F50
Drive power rating (100% DC)	8 kW

Rapid traverse

Max. X axis	100 m/min
Max. Y axis	100 m/min
Max. Z axis	30 m/min

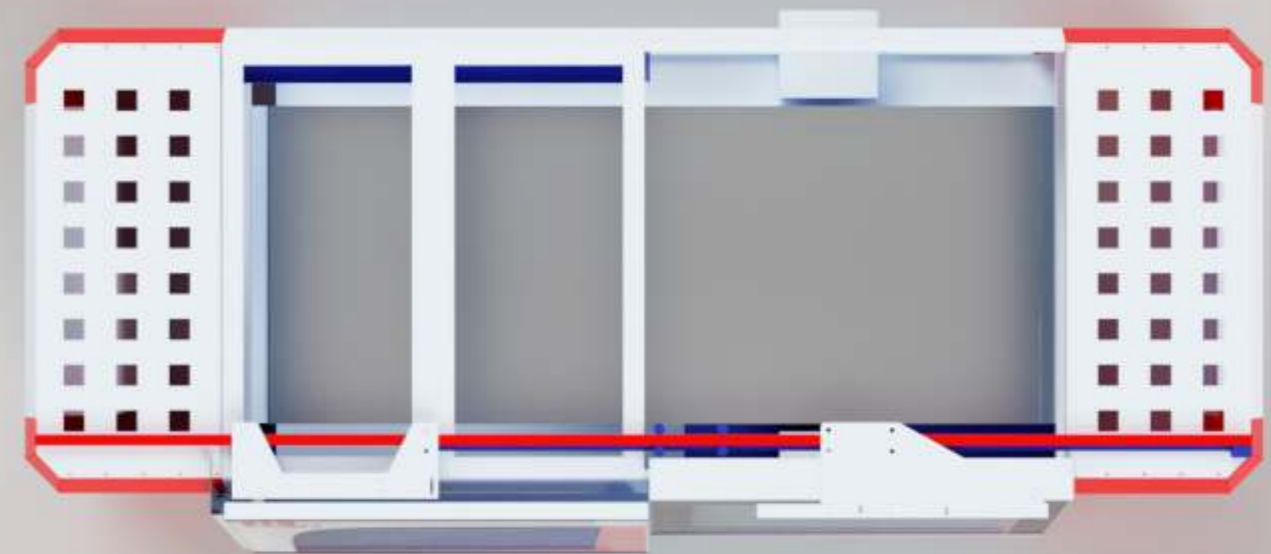

SK Series Function

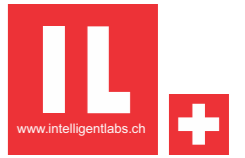

Transmission

Precision in all shapes and sizes

Perfect for high-performance drive units

Quality offered by



GÜDEL



SIEMENS

Servomotors

Siemens - made in Germany

High-precision encoder, 28 bits/revolution;
67 million ppr

Max. rotational speed: 6000rpm

Low cogging torque



Vacuum system

Powerful rotary vane vacuum pumps

Computerized control of the vacuum fields

oerlikon leybold vacuum



up to
40K rpm

Quality

assured by
hi-class brands ...



Accelerometro	Controllo ridondante velocità	Connessione Fieldbus
Air Tool	Assemblaggio Modulare	Set-up remoto sensori
Monitoraggio Temperatura Cuscinetti	Monitoraggio Temperatura Motore	Encoder

SK Series

Order List



Model range

SK 1510

Max. X travels	1,050 mm
Max. Y travels	1,600 mm

SK 1515

Max. X travels	1,600 mm
Max. Y travels	1,600 mm

SK 3015

Max. X travels	3,100 mm
Max. Y travels	1,600 mm

SK 3020

Max. X travels	3,100 mm
Max. Y travels	2,100 mm

SK 4520

Max. X travels	4,600 mm
Max. Y travels	2,100 mm

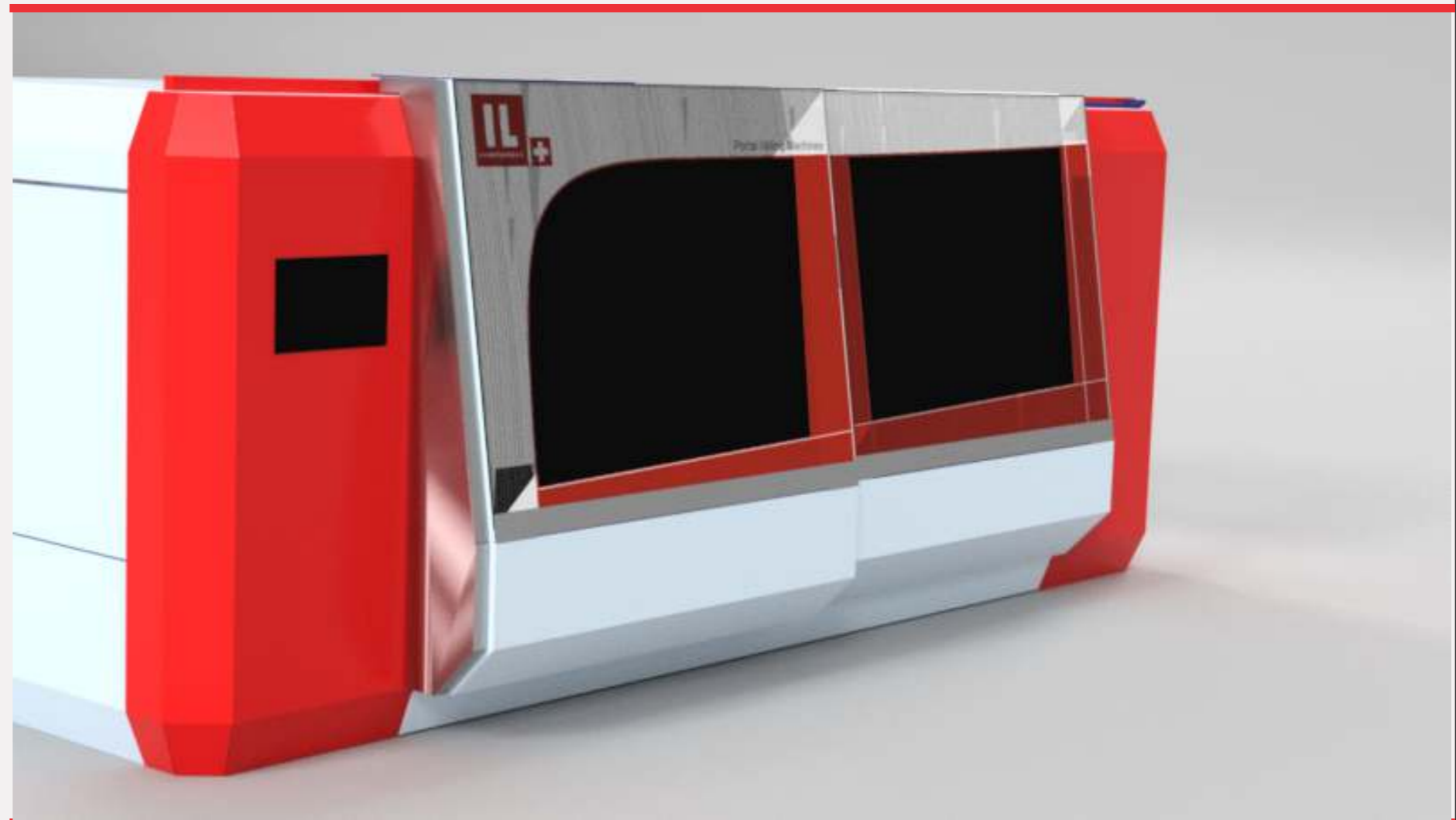

SK Series

Controller option

Notes

SIEMENS



Quality

made in Germany

Siemens 840D SL with 19" Touch Panel

Designed to be extremely user-friendly, Siemens 840D SL makes operating CNC machines easy and efficient.

The new panel is flat, features ergonomically positioned keys, completely redesigned hardware and a brand new user interface.

Conversational automatic programming function with process menu

User – friendly operator guidance screen with clear machine status display

* increase transfer speed up to 120 m/min

* increase accuracy with nano metric technologies



www.intelligentlabs.ch